

THREADED COUNTERBORE FOR BALL COUPLER

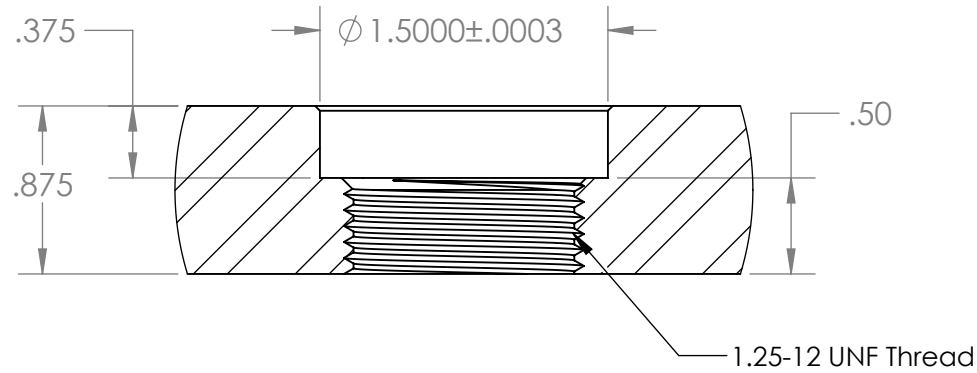
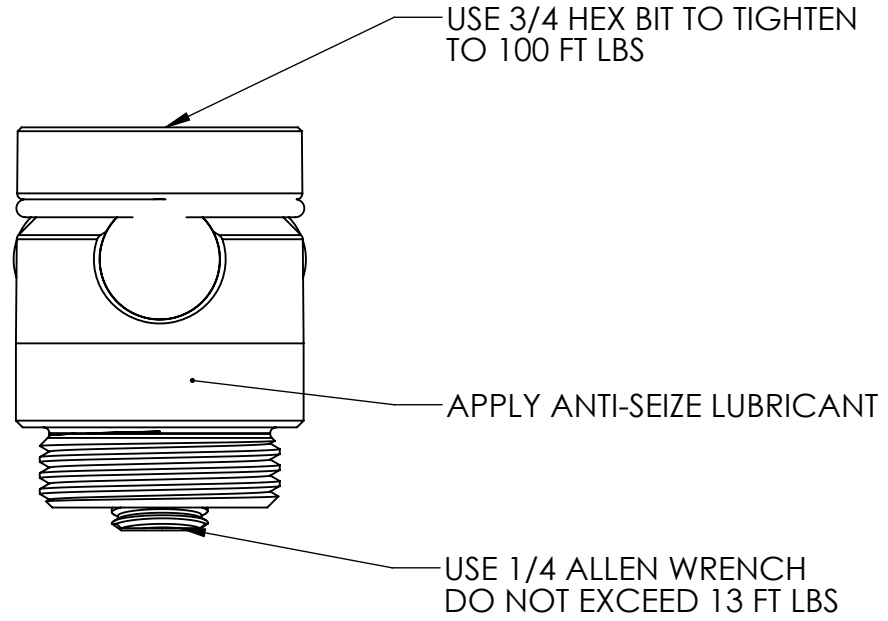

PROPRIETARY AND CONFIDENTIAL
 THE INFORMATION CONTAINED IN THIS DRAWING IS THE SOLE PROPERTY OF ORANGE VISE COMPANY LLC. ANY REPRODUCTION IN PART OR AS A WHOLE WITHOUT THE WRITTEN PERMISSION OF ORANGE VISE COMPANY LLC IS PROHIBITED.

| | | | | | | | | | | | | | | |
|-------------|---------|--------------------------------------|-----------|------|---------|-------------------------------------|--|--|-------------------|--|--|---------------------------------|--|--|
| | | UNLESS OTHERWISE SPECIFIED: | | NAME | DATE | TITLE: BALL COUPLER INSTALLATION | | | | | | | | |
| | | DIMENSIONS ARE IN INCHES | DRAWN | SUN | 5/15/13 | | | | SIZE DWG. NO. REV | | | | | |
| | | TOLERANCES: | CHECKED | | | | | | | | | SCALE: 1:1 WEIGHT: SHEET 1 OF 1 | | |
| | | FRACTIONAL ± | ENG APPR. | | | | | | | | | | | |
| | | ANGULAR: MACH ± BEND ± | MFG APPR. | | | | | | | | | | | |
| | | TWO PLACE DECIMAL ± | Q.A. | | | | | | | | | | | |
| | | THREE PLACE DECIMAL ± | COMMENTS: | | | | | | | | | | | |
| | | INTERPRET GEOMETRIC TOLERANCING PER: | | | | | | | | | | | | |
| | | MATERIAL | | | | | | | | | | | | |
| | | FINISH | | | | | | | | | | | | |
| NEXT ASSY | USED ON | | | | | | | | | | | | | |
| APPLICATION | | DO NOT SCALE DRAWING | | | | | | | | | | | | |